

Elettropompe sommergibili inox

TENAX

DN 80



Elettropompe sommergibili monocali per acque cariche dotate di controflangia
Submersible single channel electric pumps for very foul waste water,
featuring a counter flange

Prevalenza: 20,5 mt ÷ 30,5 mt

Portata: 72 m³/h ÷ 96 m³/h

Pot. nominale: 2,25 kW (3,0 Hp) ÷ 4,5 kW (6,0 Hp)

Passaggio solidi 50 mm

Pump head: 20,5 mt ÷ 30,5 mt

Delivery: 72,0 m³/h ÷ 96,0 m³/h

Rated output: 2,25kW (1,5 Hp) ÷ 4,5 kW (6,0 Hp)

Solid matter bypass 50 mm

Applicazioni

- Svuotamento di fosse di decantazione, pozzi di raccolta liquami.
- Pompaggio di acque luride anche con corpi solidi e parti fibrose in sospensione.
- Movimentazione di acque luride ad uso domestico ed industriale.

Applications

- Decantation pit, slurry collection pit pump out.
- Pumping of sewage even with solid bodies and fibrous parts in suspension.
- Domestic and industrial lavatory/black water handling systems.

CARATTERISTICHE DI COSTRUZIONE		DESIGN ENGINEERING	
• Elettropompa a unica camera		• <i>Single chamber electric pump</i>	
• Motore a bagno d'olio (biodegradabile e dielettrico) per raffreddamento e lubrificazione cuscinetti		• <i>Oil bath motor (biodegradable and dielectric) for cooling and bearing lubrication</i>	
• Doppia tenuta meccanica:	lato motore a bagno d'olio lato pompa bagno d'acqua	• <i>Double mechanical seals:</i>	<i>engine face: oil bath pump face: water bath</i>
• Immersione massima: mt 5		• <i>Permissible draught of water: 5 mt</i>	
• Grado di protezione: IP 68		• <i>IP 68 protection class</i>	
• Classe di isolamento: F		• <i>Class "F" insulation</i>	
• Temperatura max liquido pompato:	25°C con pompa parzialmente immersa 35°C con pompa totalmente immersa	• <i>Max pumped liquid temperature:</i>	<i>25°C with partially submerged pump 35°C with totally submerged pump</i>
• Passaggio libero:	50 mm	• <i>By pass section:</i>	50 mm
• Versioni		• <i>Versions</i>	
Trifase:	220-277V/50Hz o 380-480V/50Hz e 220-277V/60Hz o 380-480V/60Hz con protezione da sovraccarico a cura dell'utente	• <i>Three Phase:</i>	<i>220-277V/50Hz or 380-480V/50Hz and 220-277V/60Hz or 380-480V/60Hz with overload protection care of the User</i>
• Potenza motore:	da 3 Hp a 6 Hp	• <i>Motor power:</i>	<i>from 3 Hp up to 6 Hp</i>
• Cavo standard:	10 metri H07RN-F	• <i>Standard cable features:</i>	<i>10 meters H07RN-F</i>

Speciali voltaggi e frequenze a richiesta

Optional:

- Sistemi di discesa DN80 per impianti fissi
- Sensori termici per protezione motore

Customised voltage and frequency rating available on demand

Optional:

- Down stroke guide rail systems DN80 for fixed plants
- Thermal sensor for motor protection

TABELLA MATERIALI - MATERIALS TABLE

Pos.	COMPONENTI COMPONENTS	MATERIALE MATERIALS
A	Carcassa esterna External housing	Acciaio inox aisi 304 Din 1.4301 / Stainless steel
B	Girante Impeller	Acciaio inox aisi 316 Din 1.4401 / Stainless steel
C	Albero (lato pompa) Shaft (pump side)	Acciaio inox aisi 316 Din 1.4401 / Stainless steel
D	Tenuta meccanica Lato motore Motor face	Grafite-ceramica Graphite-ceramic
	Mechanical seal Lato pompa Pump face	Carburo di silicio-ceramica Silicon carbide-ceramic
E	O-ring	Nbr
H	Carcassa motore Motor housing	Acciaio inox aisi 304 Din 1.4301 /Stainless steel
I	Coperchio + maniglia Cover + handle	Acciaio inox aisi 304 Din 1.4301 /Stainless steel
N	Base d'aspirazione Suction base	Acciaio inox aisi 304 Din 1.4301 /Stainless steel
P	Corpo pompa Pump body	Acciaio inox aisi 304 Din 1.4301 /Stainless steel
R	Flangia portamotore inferiore Lower motore-flange	Acciaio inox aisi 304 Din 1.4301 /Stainless steel
S	Flangia portamotore superiore Upper motore-flange	Ghisa (G20) Cast iron
T	Controflangia d'aspirazione Suction counter-flange	Acciaio inox aisi 304 Din 1.4301 /Stainless steel

Prestazioni / Performance Data 50Hz

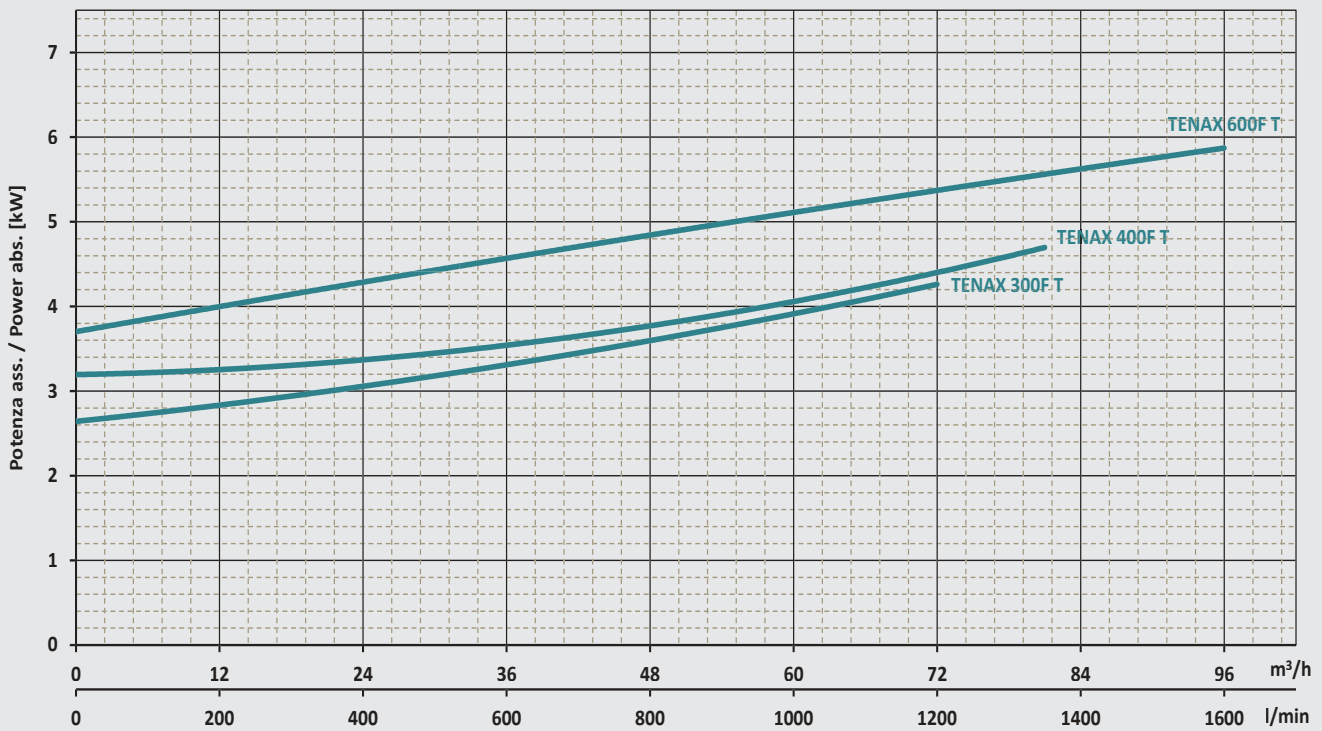
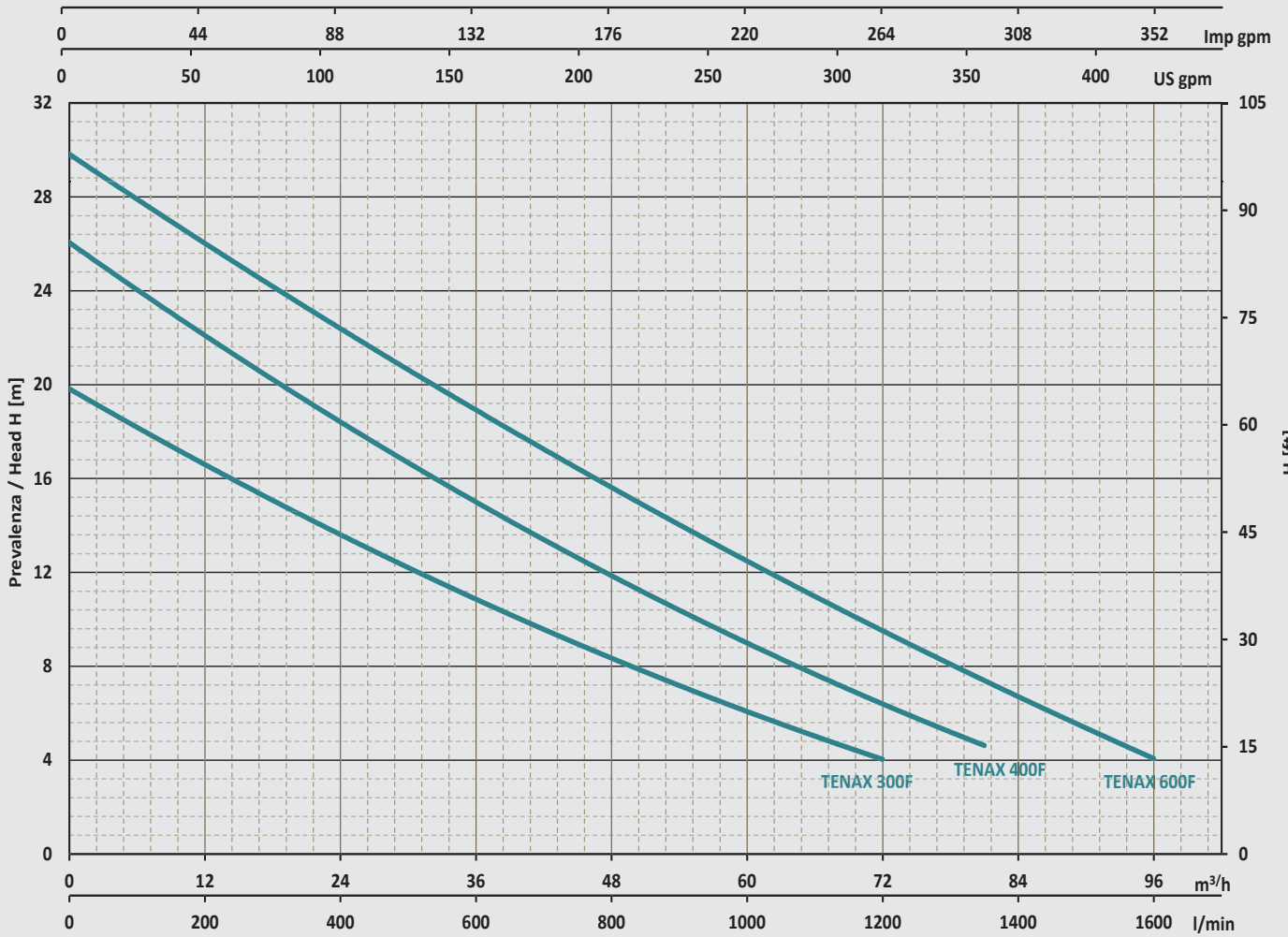

Portata / Flow rate Q

Le prestazioni valgono per liquidi con densità $\rho = 1,0 \text{ kg/dm}^3$ ed una viscosità $\nu = 1 \text{ mm}^2/\text{s}$
 The performance data holds true for liquids with a $\rho = 1,0 \text{ kg/dm}^3$ density and a $\nu = 1 \text{ mm}^2/\text{s}$ viscosity.

		DATI ELETTRICI - ELECTRICAL DATA								DATI IDRAULICI - HYDRAULIC DATA										
Codice	Modello	Phase	Volt	Hz	P ass.	I ass.	P nom.		Capacitor		m3/h	0	3	15	30	39	57	72	81	96
Code	Model				kW	A	kW	HP	µF	VC										
TNC3005/F	TENAX 300F c T	3 ~	400	50	3,4	6,9	2,25	3	-	-	20,5	18,6	15,2	12,2	10,5	6,9	3,8	-	-	-
TNC4005/F	TENAX 400F c T	3 ~	400	50	4	8,1	3	4	-	-	H (m)	26,5	25	20,5	16,5	14,3	10,4	6	4,6	-
TNC6005/F	TENAX 600F c T	3 ~	400	50	5,5	9,5	4,5	6	-	-	30,5	28,7	24,4	20,4	18	13,8	9,4	7,8	3,7	-

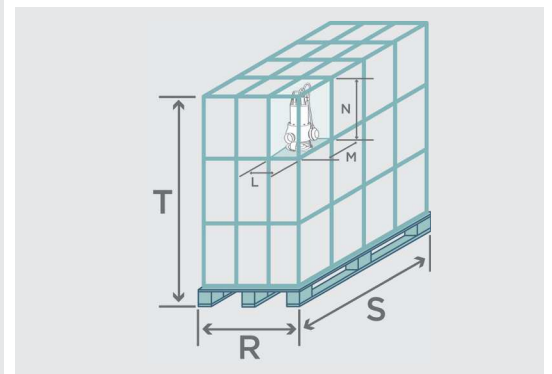
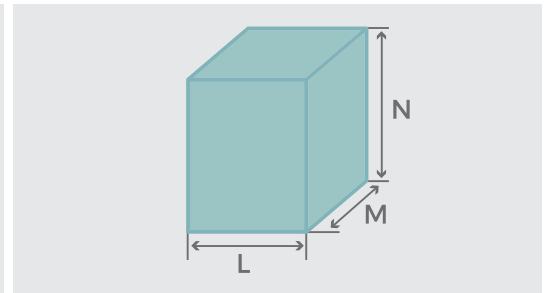
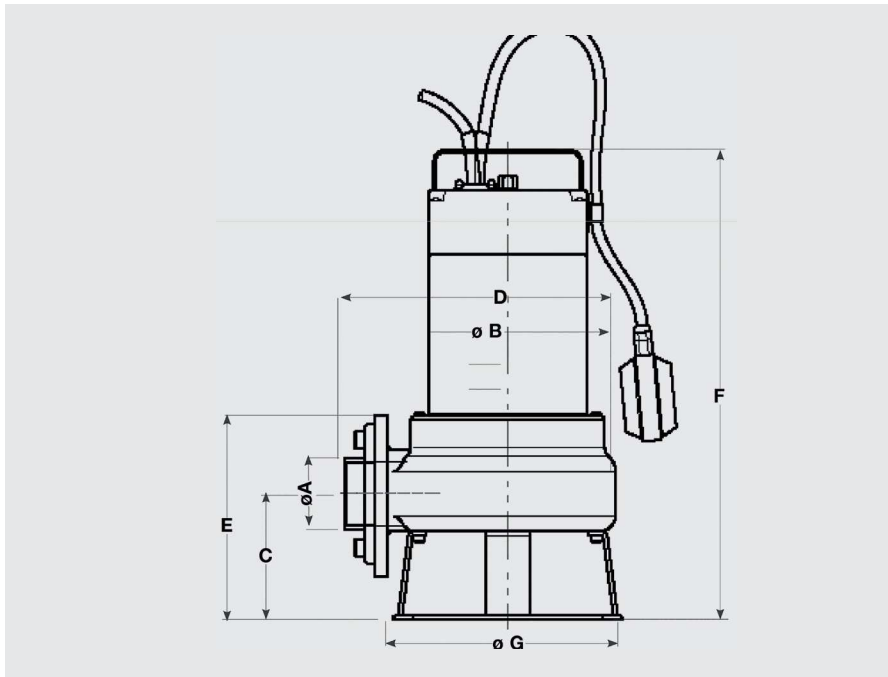

MODELLO MODEL	DIMENSIONI POMPA PUMP DIMENSION						
	A	B	C	D	E	F	G
TENAX 300 F c T	3"	119	190	390	285	662	279
TENAX 400 F c T	3"	119	190	390	285	662	279
TENAX 600 F c T	3"	119	190	390	285	662	279

MODELLO MODEL	DIMENSIONI SCATOLA PACKING DIMENSION				DIMENSIONI PALLET PALLET DIMENSIONS				
	L mm	M mm	N mm	Peso Weight kg	R mm	S mm	T mm	NR scatole	PESO Kg
TENAX 300 F c T	720	400	260	28,0	800	1200	900	9	280
TENAX 400 F c T	720	400	260	33,0	800	1200	900	9	325
TENAX 600 F c T	720	400	260	37,0	800	1200	900	9	360

*..c Monocanale chiusa / Close single channel